

MedAir 2200

Compressed Airline Monitor for Medical Air Systems



PRODUCT HIGHLIGHTS

- Continuous real-time gas monitoring of hospital compressed airlines
- Monitors oxygen, carbon monoxide and dew point simultaneously
- User programmable alarms and relays
- Meets Grade D breathing and NFPA 99 requirements
- Low flow alarm
- Field replaceable sensors

MedAir 2200 is a compact, easy to install and operate compressed airline monitor that can continuously and simultaneously monitor up to four gases in real-time using internally mounted sensors. MedAir 2200 is typically configured to monitor hospital compressed air for carbon monoxide, oxygen and dew point. MedAir 2200 is designed to meet OSHA monitoring requirements for Grade D breathing air, NFPA 99 "Medical Air System Guidelines" and is UL and CSA certified for "Medical Electrical Equipment Safety Requirements" (UL/IEC 60601-1 and CSA 22.2, No. 601-1).

MedAir 2200 has a user-friendly software interface and is operated by using push buttons and LCD display. The general instrument set-up configuration and maintenance functions are password protected to prevent unauthorized personnel from gaining access to secure data. The maintenance and operation menu functions allow the user to change alarm points, program relays and perform calibrations in the field. The monitor uses a backlit digital display, a power

LED and a fault LED indicator, integrated audible and visual alarms with two alarm threshold indicators and features a four minute audio defeat option for alerts below alarm level maximum. The sample inlet pressure must be regulated to 55 psi. It has an integral electronic flow sensor with a fault alarm to monitor for low flow conditions of less than 0.2 liter per minute.

MedAir 2200 is ENMET's most advanced compressed airline monitor for medical air systems, specifically designed for hospital applications. ENMET has a complete line of versatile compressed airline monitors, which can be used in a wide variety of industrial applications from aerospace to pharmaceutical and can be easily adapted to meet your specific needs for compressed airline monitoring.

For additional information on the MedAir 2200, contact the ENMET sales department for help in designing a MedAir 2200 to meet your requirements for air quality monitoring of hospital compressed air systems.

MedAir 2200

GENERAL SPECIFICATIONS

Display:	High-contrast, backlit
Alarms:	Visual: LEDs Audible: Piezoelectric horn, 95 dB at 2 feet
Alarm Relays:	5 programmable gas relays plus fault. All relays are programmable latching or non-latching, dry SPDT, 10 amps (resistive load only) at 110 VAC.
Operating Power:	100 to 240 VAC and/or 12 VDC, 15 Watts
Sensor Types:	CO and O ₂ : Electrochemical Dew Point: Thin-Film Polymer
Sensor Life:	CO: 1-3 years, with calibration O ₂ : 1-2 years, with calibration Dew Point: 2 years, replacement
Response Times:	
Dew point:	T ₉₀ = 10 seconds for -40° to 50°F step change
CO:	T ₉₀ = 30 seconds
O ₂ :	T ₉₀ = 15 seconds
Inlet Pressure:	Must be regulated to 55 psi (user provided)
Flow Rate:	1/2 liter per minute (1 SCFH)
Enclosure:	Thermoplastic box with clear, hinged front cover, designed for NEMA 12 and 4X
Dimensions:	9.3 W x 11.9 H x 6.1 D inches (21.3 W x 30.3 H x 15.4 D cm)
Weight:	8 lbs. (3.6 kg)
Approvals:	UL 60601-1, IEC 60601-1 & CSA 22.2, No. 601.1

DIMENSIONS

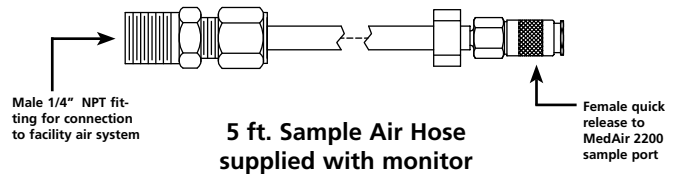
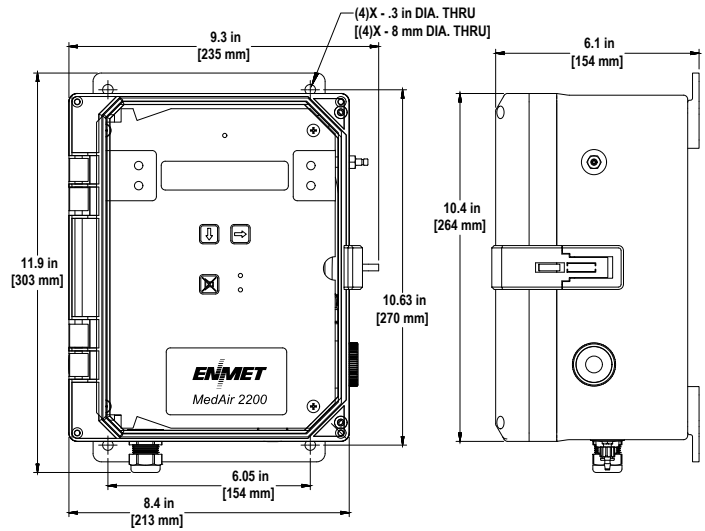

STANDARD CALIBRATIONS

Range:	Alarm Points:
<ul style="list-style-type: none"> • 0-50 ppm CO • 0-30% O₂ Deficiency • 0-30% O₂ Abundance • -112° to +68°F Dew Point (-80° to +20°C) 	<ul style="list-style-type: none"> • 10 and 20 ppm CO • 19.5% O₂ Deficiency • 23.5% O₂ Abundance • Alarm 1: +35°F Dew Point (+1.6° C) • Alarm 2: +50°F Dew Point (+10° C)

ORDERING INFORMATION

Description	Part No.
MedAir 2200, CO Monitor	03420-000
MedAir 2200, CO and Oxygen Monitor	03420-001
MedAir 2200, CO and Dew Point Monitor	03420-005
MedAir 2200, CO, Oxygen and Dew Point Monitor	03420-006
MedAir 2200, CO, Dew Point, O ₂ and CO ₂ Monitor	03420-008
MedAir 2200, Dew Point only Monitor	03420-010
Gas Regulator Assembly for 34 liter steel cylinders, CO & O ₂	03700-500
Gas Regulator Assembly for 103 liter steel cylinders, CO ₂	03700-501
Calibration Equipment Case	73083-000

Calibration Gas and Accessories - See price list



WARNING:

The MedAir 2200, without the oxygen monitoring circuitry, should be used only where there is complete assurance that inert gas cannot be accidentally injected into the breathing air line.

Loss of primary power renders continuous gas monitors inoperative. Contact factory for specifications and pricing for backup battery systems compatible with ENMET monitors.

